



Groove

MADE IN ITALY



SOLUTIONS FOR VINEYARDS



CATALOGUE 2022_V2

1 ● VULTUS - MULTI-FUNCTIONAL TOOL CARRIER	
1.1 Development	<i>pag. 3</i>
2 ● VULTUS SINGLE, MULTI-FUNCTIONAL TOOL CARRIER	
2.1 Technical features	<i>pag. 4</i>
2.2 Set up	<i>pag. 4</i>
2.3 Mechanical tools	<i>pag. 5</i>
2.4 Hydraulic tools	<i>pag. 6</i>
3 ● VULTUS DOUBLE, DOUBLE MULTI-FUNCTIONAL TOOL CARRIER	
3.1 Technical features	<i>pag. 7</i>
3.2 Set up	<i>pag. 7</i>
3.3 Mechanical tools	<i>pag. 8</i>
3.4 Hydraulic tools	<i>pag. 9</i>
4 ● TRIDER - MECHANICAL STUMP ERADICATOR	
4.1 The development	<i>pag. 11</i>
4.2 Technical features	<i>pag. 12</i>
4.3 Set up	<i>pag. 12</i>
GENERAL SALES CONDITIONS	<i>pag. 14</i>

VULTUS

MULTI-FUNCTIONAL TOOL CARRIER

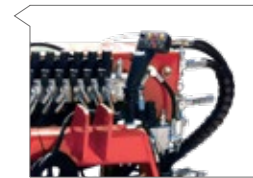
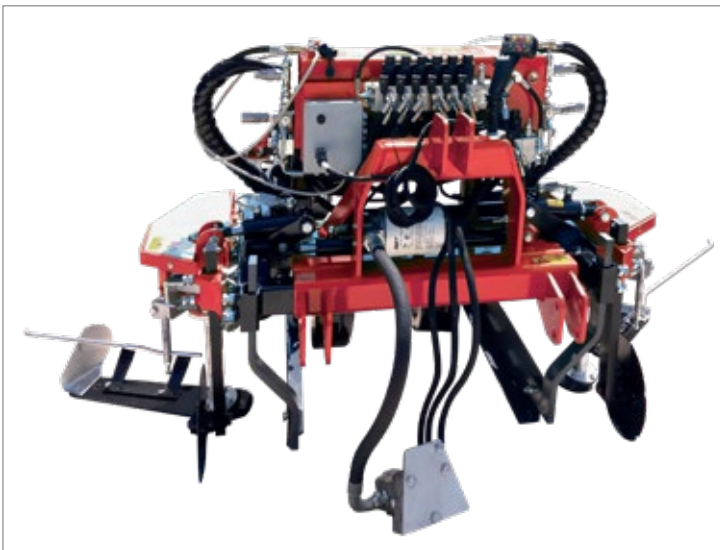

1.1 Development

The multi-functional tool carriers by LACRUZ® are pre-arranged for mechanical and hydraulic accessories and they are conceived for the maintenance of the soil in the inter-row through a mechanical working of the soil with respect to the plant. Developed on a steel structure, it is a perfect combination of sturdiness and easy handling and it is conceived to grant the best performance also in difficult working conditions, such as steep slopes and heavy soils.

The tool is equipped with a hydraulic device, allowing to regulate the work of the accessories and an automatic cooling system.

The independent hydraulic system offers the possibility to use this device also with tractors with a reduced oil flow, avoiding problems of flow rate and overheating. Height, width and grade are then regulated by a joystick and they allow to adapt the machine to different working needs.

The development of this machine arises from the necessity of reducing the use of chemical products for the management of the weeds in the soil, and also of optimizing the costs and working time. The hydraulic system of the tool works also with oil of vegetal origin.

The versatility of this multi-functional tool carriers by LACRUZ® is given also by the possibility of choosing the single or double version, front or rear mounting, with cardan shaft onboard or rear lifted with direct pump.

LACRUZ® offers also a wide range of accessories to cope with the several soil conditions, equipped with double-effect sensor arms for a better control and higher precision in use.

VULTUS SINGLE

MULTI-FUNCTIONAL TOOL CARRIER

2.1 Technical features

Encumbrance	Frame length			Weight
146 cm	120 cm	170 cm	40	440 kg

2.2 Set up

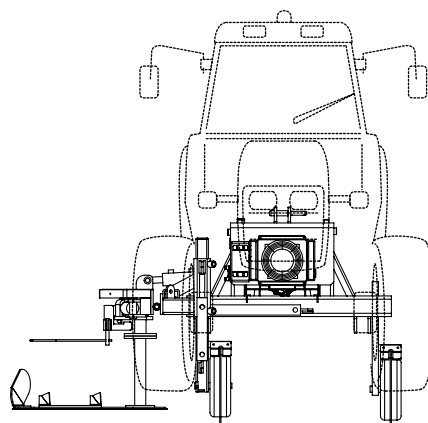
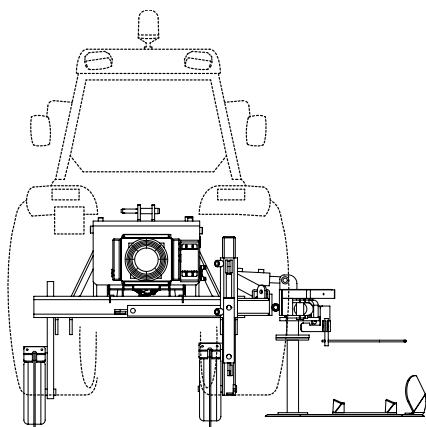

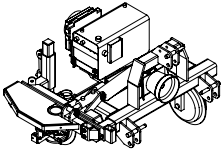
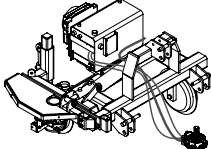
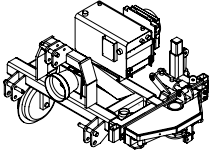
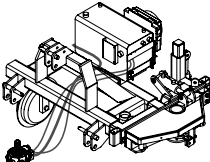







Code	Image	Technical features
INT01		Vultus Single tool carrier, rear lifted with cardan shaft.
INT11		Vultus Single tool carrier, rear lifted with direct pump.
INT21		Vultus Single tool carrier, front lifted with cardan shaft.
INT31		Vultus Single tool carrier, front lifted with direct pump (to the rear PTO).

VULTUS SINGLE

MULTI-FUNCTIONAL TOOL CARRIER



2.3 Mechanical tools

Code	Image	Technical features
INTADEA		Front chisel.
INTADAA		Front right chisel Ø 34 cm.
INTAPAD		Adjustable right soil deflector.
INTAPMD		Adjustable right soil deflector with shock absorber.
INTALI6D		Right reversible interrow blade 60 cm with straight sensor arm.
INTALI7D		Right reversible interrow blade 70 cm with straight sensor arm.
INTADDD		Independent ridging disk, right, Ø 45 cm, adjustable.
INTAVOD		Tiller plough, right, with sensor arm.





VULTUS SINGLE

MULTI-FUNCTIONAL TOOL CARRIER

2.3 Mechanical tools

Code	Image	Technical features
INTAZRD		2-disks rotary hoe with upper support, right side.
INTAZR3D		3-disks rotary hoe with upper support, right side.



2.4 Hydraulic tools

Code	Image	Technical features
INTAD2D		Modular set with 2 hoeing discs, right, Ø 32 cm, hydraulic engine, with sensor arm.
INTAD3D		Modular set with 3 hoeing discs, right, Ø 32 cm, hydraulic engine, with sensor arm.
INTAE4D		Power harrow, right, 3 knives H. 18 cm, Ø 40 cm, hydraulic engine, with sensor arm.
INTAE5D		Power harrow, right, 3 knives H. 18 cm, Ø 50 cm, hydraulic engine, with sensor arm.
INTASPD		Shoot remover, right, Ø 6 mm whip, hydraulic engine, with sensor arm.

VULTUS DOUBLE

MULTI-FUNCTIONAL TOOL CARRIER

3.1 Technical features

Encumbrance	Frame length			Weight
175 cm	120 cm	200-310 cm	80	740 kg

3.2 Set up

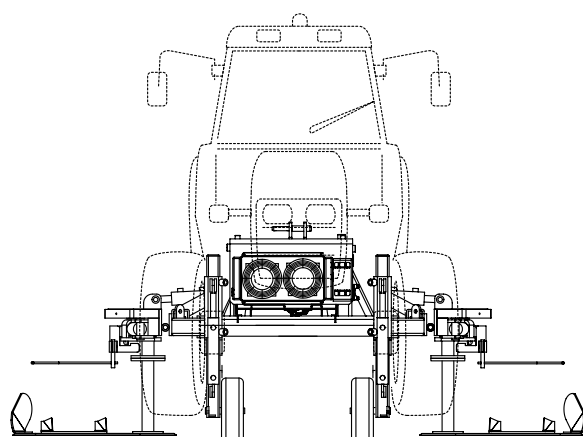
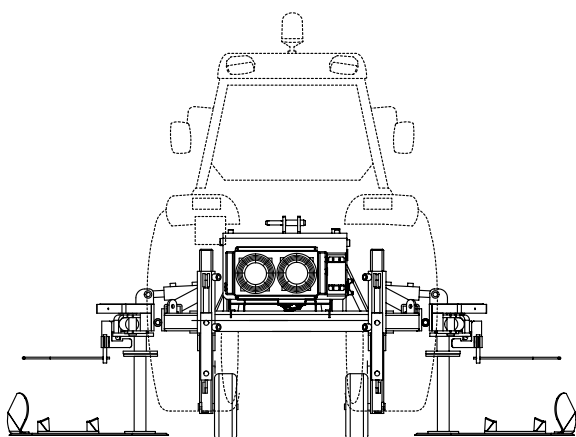

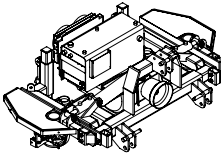
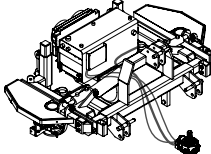
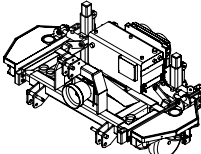
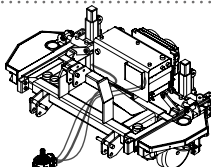







Code	Image	Technical features
INT02		Vultus Double tool carrier, rear lifted with cardan shaft.
INT12		Vultus Double tool carrier, rear lifted with direct pump.
INT22		Vultus Double tool carrier, front lifted with cardan shaft.
INT32		Vultus Double tool carrier, front lifted with direct pump (to the rear PTO).

VULTUS DOUBLE

MULTI-FUNCTIONAL TOOL CARRIER







3.3 Mechanical tools

Code	Image	Technical features
INTCDE		Pair of front eradicating chisels.
INTCDA		Pair of front tracking disks, Ø 34 cm.
INTCPA		Pair of adjustable soil deflector.
INTCPM		Pair of adjustable soil deflector with shock absorber.
INTCLI6		Pair of reversible interrow blade 60 cm with straight sensor arm.
INTCLI7		Pair of reversible interrow blade 70 cm with straight sensor arm.
INTCDD		Pair of independent wedding tiller disks, Ø 45 cm.
INTCVO		Pair of tiller plows, with straight sensor arms.
INTCSA70R		Pair of Ø 70 cm finger hoes with support. Red type.

VULTUS DOUBLE

MULTI-FUNCTIONAL TOOL CARRIER





3.3 Mechanical tools

Code	Image	Technical features
INTCSA70G		Pair of Ø 70 cm finger hoes with support. Yellow type.
INTCSA70A		Pair of Ø 70 cm finger hoes with support. Orange type.
INTCSA54R		Pair of Ø 54 cm finger hoes with support. Red type.
INTCSA54G		Pair of Ø 54 cm finger hoes with support. Yellow type.
INTCSA54A		Pair of Ø 54 cm finger hoes with support. Orange type.
INTCZR		Pair of 2 disks rotary hoe with upper support, right side.
INTCZR3		Pair of 3 disks rotary hoe with upper support, right side.

VULTUS DOUBLE

MULTI-FUNCTIONAL TOOL CARRIER

3.4 Hydraulic tools

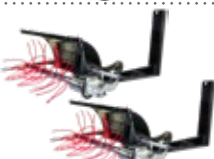
Code	Image	Technical features
INTCD2		Pair of 2 disks wedding set, modular, Ø 32 cm, hydraulic engine, with sensor arms.
INTCD31		Pair of 3 disks wedding set, modular, Ø 32 cm, hydraulic engine, with sensor arms.
INTCE4		Pair of power harrows, 3 knives H. 18 cm, Ø 40 cm, hydraulic engine, with sensor arms.
INTCE5		Pair of power harrows, 3 knives H. 18 cm, Ø 50 cm, hydraulic engine, with sensor arms.
INTCSP		Pair of Shoot removers, Ø 6 mm whip, hydraulic engine, with sensor arms.

TRIDER

MECHANICAL STUMP ERADICATOR



4.1 Development

The mechanical stump eradicator by LACRUZ® is a tool conceived to work with tracked or wheeled tractors. The system works through a mechanical transmission and allows the total removal of roots in row plantations such as vineyard, orchards, poplars and others.

Thanks to the motion of the tractor, harrows and blades cut portions of the soil, oscillating bars and rotors help extracting the stumps and separating the dirt from roots, that are left on the ground behind the machine.

Soon after the passage of the stump eradicator, the soil is practically ready for new cultivations and the roots left clean on the ground can be easily collected and brought to recycling and biomass plants. The removal of stumps and roots which is usually an expensive but necessary operation, becomes in this way an easier, faster and more cost effective work, especially in comparison with the traditional methods of plant extraction.

LACRUZ® has developed 4 models of stump eradicators, varying according to the working width, diameters of the stumps and depth of the roots to be removed.





TRIDER

MECHANICAL STUMP ERADICATOR

4.2 Technical features

Code	Length	Width	Height			 HP
SR80M	340 cm	155 cm	170 cm	80 cm	50 cm	120 HP
SR100M	340 cm	170 cm	170 cm	100 cm	60 cm	150 HP
SR120M	350 cm	200 cm	200 cm	120 cm	70 cm	250 HP
SR150M	350 cm	200 cm	200 cm	150 cm	70 cm	250 HP

4.3 Set up

Code	Image	Description
SR80M		Mechanical stump eradicator. Made of Hardox 450 steel. Length: 3.40 m. Width: 1.55 m. Height: 1.70 m. Weight: 1480 kg. Min. horsepower required 120 HP. Working width 0.80 m. Working depth (max) 0.50 m. Equipped with a cardan joint 2100N/M, with shearing bolt. 540 rpm with working PTO. 900 rpm motor of the tractor. Three-point linkage cat. 3. Standard PTO connection: 1" 3/8 Z6.
SR100M		Mechanical stump eradicator. Made of Hardox 450 steel. Length: 3.40 m. Width: 1.70 m. Height 1.70 m. Weight: 1870 kg. Min. horsepower required 160 HP. Working width 1.00 m. Working depth (max) 0.60 m. Equipped with a cardan joint 2100N/M, with shearing bolt. 540 rpm with working PTO. 900 rpm motor of the tractor. Three-point linkage cat. 3. Standard PTO connection: 1" 3/8 Z6.
SR120M		Mechanical stump eradicator. Made of Hardox 450 steel. Length: 3.50 m. Width: 2.00 m. Height 2.00 m. Weight: 2440 kg. Min. horsepower required 250 HP. Working width 1.20 m. Working depth (max) 0.70 m. Equipped with a cardan joint 2100N/M, with shearing bolt. 540 rpm with working PTO. 900 rpm motor of the tractor. Three-point linkage cat. 3. Standard PTO connection: 1" 3/8 Z6.
SR150M		Mechanical stump eradicator. Made of Hardox 450 steel. Length: 3.50 m. Width: 2.00 m. Height 2.00 m. Weight: 2440 kg. Min. horsepower required 250 HP. Working width 1.50 m. Working depth (max) 0.70 m. Equipped with a cardan joint 2100N/M, with shearing bolt. 540 rpm with working PTO. 900 rpm motor of the tractor. Three-point linkage cat. 3. Standard PTO connection: 1" 3/8 Z6.

TRIDER

MECHANICAL STUMP ERADICATOR



Conceived for extracting stumps from the ground in all kind of row-planted cultivations

Reduced working time in comparison to the job of non-specialized machines

Stumps extracted with roots already cleaned from their ground blocks

No grinding of stumps on plantations and reduced risk of spreading viruses

Ideal to produce stumps and roots for recycling and production of biomass

Even and uniform ground after the extirpation job



GENERAL SALES CONDITIONS

These general conditions govern the contractual sales relationships between LaCruz® S.r.l. (hereinafter Seller) and its customers (hereinafter Buyer), and form an integral part of the Purchase Proposal.

1. DEFINITIONS AND EFFECTIVENESS OF THE GENERAL CONDITIONS

In the purchase proposal/sale contract, the following definitions shall apply:

new: new machine;

overhauled: machine recently overhauled/reconditioned;

to be overhauled: used machine for which it is recommended to perform some maintenance / replacements / interventions to be agreed in advance with the customer;

seen and liked in the state in which it is: used machine;

not working: used machine out of order;

Any provisions that derogate from the provisions of the general purchase conditions will only be effective if expressly agreed and accepted in writing by the parties.

These general conditions shall be effective until they have been expressly revoked by the Seller or are replaced by new conditions that will become effective from the moment of the signing thereof.

2. ORDERS

The Purchase Proposal, also negotiated or discussed, sent to the Seller shall be considered definitive only if expressly accepted by the latter by signing thereof. The Purchase Proposal modified by the Seller will be understood as a new proposal and shall be expressly signed by the Buyer.

3. PRICE

The sale price is that resulting from the price list in force at the time of signing the purchase proposal, or the one negotiated between the parties and resulting in the same purchase proposal.

Unless otherwise established, the sale price is intended for goods packed according to the uses of the sector in relation to the agreed means of transport, as it is also understood that any other expense or charge shall be borne by the Buyer. Unless otherwise agreed in writing, the price does not include VAT, packaging, customs, transport and accessory costs.

Upon signing this contract, the Buyer will pay, where requested by the Seller, a sum indicated by the Seller, as a deposit. The Buyer's proposal shall become accepted and binding for the Seller at the time of signing thereof by both parties, together with the general sale conditions. Non-acceptance by the Seller may not give rise to claims for any compensation for damages and shall only result in the reimbursement of any sums already paid by the Buyer.

4. TRANSPORT OF GOODS

If a sale with transport by carrier has been agreed, the risks shall be transferred to the Purchaser with the delivery of the goods to the first carrier: any claims for breakages, deteriorations, tampering or shortcomings shall be reported to the carrier in accordance with the terms established by law, however appropriately notifying the Seller. Unless otherwise agreed in writing, delivery shall take place ex works at the Seller's factory in via Concordia 16 ZI-31046 Oderzo (Treviso). The Seller's obligation to deliver shall be deemed fulfilled when the same has provided the goods directly to the Buyer or to a carrier.

Any agreements notwithstanding the foregoing, also with reference to the associated risks, shall result in the Purchase Proposal and in the Sale Contract, in particular where transport methods are agreed as defined according to the Incoterms©2010.

5. EXPORT

In case of export of the purchased goods, the originator undertakes to obtain, at own expense, all the documents necessary for export (ex. export and customs permits, etc.). LaCruz shall not be liable for the lawfulness of the export of goods as well as for compliance thereof with the regulatory and technical requirements of the country of import. In addition, LaCruz shall also not be liable for the conformity of the goods to the technical level of the importing country.

6. DELIVERY TERMS

Unless otherwise agreed, the delivery terms provided in the purchase proposal / sale contract are purely indicative and not essential; any delays in delivery may not entitle the Buyer to indemnity and/or compensation of any kind.

Any changes required during the production phase shall however release the Seller from compliance with the agreed terms. In this case, the delivery terms and conditions shall be renegotiated. In the case of collection of the goods by the Purchaser, the same undertakes to collect them when made available, within and no later than five days from the telephone or written communication (also by e-mail) of availability.

In case of non-collection within the established terms, the Seller shall have the right to ask for a penalty equal to 5% of the sale amount for each day of delay, always subject to compensation for greater damage. Furthermore, if the delay of the Purchaser, with respect to the term set for the collection of the goods, shall be greater than 30 days, the seller shall have the right to terminate the purchase proposal/sale contract due to non-fulfillment of the purchaser, retaining any amounts already paid by the purchaser; the seller may also claim the costs incurred for any restorations agreed during negotiation and definition of the order, without prejudice to any further rights, in particular, compensation for any greater damage.

7. CAUSES OF IMPEDIMENT

The Seller and/or the Purchaser may not be held liable for the failure, even partial, to fulfill one of their obligations if said failure is due to an impediment independent of their will, therefore reasonably unpredictable at the time of signing the purchase proposal / sale contract, and said impediment could not have been avoided in any way. In the presence of said impediment, the Parties shall be required to communicate it without delay.

Similar communication shall be provided as soon as the event that caused the impediment shall cease. In case of omission in the above communication, the defaulting party shall be required to compensate for any damage caused. In any case, if the impediment shall continue for a period exceeding 20 days, each party shall have the right to terminate the purchase proposal / sale contract by written communication to the other party, excluding any charges or additional rights from arising/resulting in this case.

8. TESTING

In relation to the sale of machines, for which on site testing is required, the Buyer undertakes to reimburse the Seller for any costs that may have to be incurred for travel and for specialized personnel required for testing.

9. PRODUCT WARRANTY. CLAIMS

Purchased goods shall be verified and checked upon delivery. Any discrepancies regarding the quantity, kind or type of products sold, as well as any claims regarding defects / non-conformities recognizable with the use of normal diligence, shall always be reported in writing within a maximum of 8 (eight) days from receipt of the goods, with analytical description in order to facilitate and allow immediate verification. After said term, the goods shall be considered to all effects as accepted and not contested; furthermore, the use and/or installation of any goods that have recognizable defects, shall exclude the possibility of disputes or claims regarding the defects. The intervention of the Seller for the sole purpose of verifying the reported defects shall not constitute recognition thereof.

The goods shall be guaranteed by the Seller for design, material and manufacturing defects, for a period of 12 (twelve) months from the date of delivery thereof.

Defects or flaws in the goods, not recognizable through diligent verification, shall be reported in writing to the Seller, via certified e-mail (PEC), under penalty of forfeiture, within 8 (eight) days of discovery thereof, and in any case not beyond the above warranty period. Any claims shall specify precisely the defect found; and the goods disputed shall always be made available to the Seller's agents for verification thereof.

Any disputes within the terms and in the manner described above shall not result in contract termination, but at the Seller's discretion, in the repair or replacement of defective products, if it is not verified that the flaws/defects are attributable to Buyer.

In this case, if the Seller nevertheless decides to carry out the repairs/replacements, they shall not be understood as recognition of the flaw and will therefore be charged to the Buyer. Except in cases of willful misconduct or gross negligence, the foregoing excludes any other liability of the Seller however originating from the goods supplied or from resale thereof. In particular, compensation and/or indemnities for damages, direct or indirect, of any nature deriving from the failure or limited use of the goods may not be claimed.

Any disputed goods shall be sent back free of charge to the Seller's address and accompanied by a specific return document. If that the Seller shall send goods to replace defective ones before receiving them, the Buyer shall return the flawed goods to the Seller within 15 days of receiving the replacements. The replaced goods shall become the property of the Buyer. If the Buyer, if not authorized in writing by the Seller, shall not return the defective products within the aforementioned term, it shall be required to pay for the goods sent in replacement. The costs and risks of transporting both defective goods and repaired or replaced goods shall be the responsibility of the Buyer.

The Buyer declares to have been informed in the purchase proposal / sale contract of the status of the goods purchased. The Buyer also declares to take note of the fact that any conformity defects may be referred to the age of

the goods and to agree that conformity defects shall not include defects due to normal wear, lack of maintenance and failure to comply with the indications provided by the manufacturer regarding the use and maintenance of the goods. The Seller shall not provide any warranty for neglect, tampering (additions or removals of components, interventions carried out by unauthorized personnel), negligence in the installation or installations carried out in areas not compliant with the specifications communicated by the Seller, improper use of the goods, negligent conservation thereof, normal wear, force majeure or unforeseeable circumstances. The Seller declines all responsibility for any damages, directly or indirectly, to people or things as a result of failure to comply with all the provisions indicated in the specific documentation accompanying the goods, where required by law, and in particular that concerning notices regarding installation, use and maintenance.

Any claims regarding a single delivery shall not release the Buyer from the obligation to collect the remaining quantity of goods provided for in the purchase proposal / sale contract or from other purchase proposals / sale contracts signed.

10. PAYMENTS

Payments shall be made exclusively to the Seller under the conditions agreed or referred to in the purchase proposal / sale contract. The agreed payment terms are peremptory and may only be changed following a written agreement between the parties. Changes granted by Seller's agents shall be ineffective unless approved in writing by the Seller. It is understood that any claims or disputes shall not entitle the Purchaser to suspend or in any case delay the payments of the disputed goods, or those included in other purchase proposals / sale contracts. More generally, no action or exception may be carried out or opposed by the Buyer until after full payment of the goods for which said dispute or exception is raised.

The Buyer is not authorized to make any deduction from the agreed price (ex. in case of alleged defects of the goods), unless previously established in writing with the Seller.

In the event of delayed payment at the agreed deadlines, the Buyer shall be charged the interest on arrears provided for by current legislation.

Upon intervention by third parties, in particular on the occasion of foreclosures of the supply of goods, the Buyer shall immediately send a written communication to LaCruz, and notify third parties in relation to the ownership reserve of LaCruz.

11. OWNERSHIP RESERVE

The Seller shall be expressly entitled to the ownership reserve for all goods covered by the purchase proposal / sale contract until the Purchaser has fully paid to the Seller any amounts due for principal, interest and any other amounts due for any reason or in any capacity depending on this sale.

From the delivery date, the Purchaser shall be responsible for the risks and consequences deriving from any damage, theft, fire, fortuitous events or force majeure, damages to people or things, and the Purchaser, despite the occurrence thereof, shall respect all the agreed obligations and payment methods.

The Buyer undertakes not to transfer or modify the goods, even in part, without the express consent of the Seller. The Buyer also undertakes to keep them in a good state of conservation. The Buyer also acknowledges to the Seller the right to verify the state of conservation of the goods until full payment thereof.

If the parties have agreed on payment by instalments, failure to pay within the agreed terms even a single instalment the amount of which exceeds one-eighth of the sale price shall give the Seller the right to consider the contract terminated. The Buyer shall be required to return the goods and the Seller shall have the right to retain, by way of indemnity, any instalments paid up to that time, except for the right to act for compensation for greater damage.

If the amount of an unpaid instalment shall be less than 1/8 of the total price, the Seller shall have the right to act for fulfillment and/or inhibit any further use of the good sold and/or act in execution for the same good or other goods of the Buyer.

If the Seller does not wish to resort to the foregoing, it may terminate benefit of the term for the Buyer. In this case, the Buyer shall be required to immediately pay the entire agreed price.

12. RETURN OF GOODS

The Seller shall not accept returns of goods unless previously authorized by the same in writing. Any returns shall in any case be intact (not dismantled), packaged (possibly in the original packaging) and accompanied by a return note, and the Buyer shall be responsible for all costs and risks.

13. SUSPENSION OR CANCELLATION OF ORDERS

If the Purchaser shall not comply, even only in part, with one of the general conditions established for the sale, as well as in case of ascertained difficulty in payments or solvency guarantees or, more generally, its economic capacity shall diminish or no longer be available, the Seller shall have the right to suspend or cancel current orders, or to subject the delivery of goods to the provision of adequate payment guarantees. In the event of order cancellation, any delivered and unpaid goods shall be returned to the Seller intact and without any alteration at the Buyer's expense within 5 days of the communication. Any delay in returning the goods shall automatically entail, in addition to returning the goods, the application of a penalty equal to 5% of the amount of the sale for each day of delay and in any case not less than 20% of the value of the goods resulting from the invoice.

Unless agreed in writing, no compensation shall be accepted between any receivables claimed by the Buyer with respect to the Seller and any payables of the Buyer, in any capacity whatsoever.

14. PRODUCT CONFORMITY IMPROVEMENTS AND MODIFICATIONS

The conformity of the goods / products with the samples shown for illustrative purposes and/or illustrations in the price lists, catalogs or similar documents shall not be guaranteed. In particular, the aesthetic aspect of products may differ from the aforementioned samples and/or images present in the aforementioned documentation.

Furthermore, also with respect to the data and information provided in the aforementioned documentation, the Seller reserves the right to make any improvements and modifications to its products, also aesthetic, deemed appropriate or necessary, and the Buyer may not raise disputes and shall not have the right to terminate / withdraw from signed purchase proposals / sale contracts and/or claim indemnities and/or request reductions in the agreed price.

15. INTELLECTUAL PROPERTY

All printed material and other documents (price lists, catalogs or other similar documents, also on IT and digital media) relating to the products are the exclusive property of the Seller. Any reproduction thereof, even if only partial, is forbidden, unless previously authorized by the Seller.

The Seller warns against the unauthorized use of its trademark, and/or other trademarks shown on the products or associated with the products supplied/sold, and/or names and distinctive signs, as well as of the models and designs relating to its products. In particular, the Purchaser may not reproduce totally and/or partially models relating to the products purchased or viewed. It is also forbidden to communicate news and information that allow any reproduction of the models. The Seller shall provide the Buyer, free of charge, at the time of delivery of the goods, with a manual containing detailed instructions for use. This manual shall become the property of the Purchaser but must be considered confidential, even after the relationship between the parties has ended.

16. DISPUTE RESOLUTION

Any disputes arising from the execution and interpretation of the contractual relationship shall be referred to the exclusive jurisdiction of the Court of Treviso.

17. FINAL PROVISIONS

These general sale conditions are governed by Italian law. If a contractual provision provided in these general sale conditions shall be invalid or null, said circumstance shall not affect the validity of the other provisions that will remain valid and effective.

18. PRIVACY

The Buyer authorizes the Seller to include related personal data on the Seller's website, as commercial reference. Furthermore, the Buyer, with specific consent to data processing, authorizes the Seller to process data for the purpose of transmitting illustrative material of the Seller's products and other commercial/promotional communications, by mail and/or e-mail. With regard to the data processed for said purposes, the Purchaser may exercise the rights provided for by current regulations.

The Buyer, pursuant to and for the purposes of EU Regulation no. 2016/679 (and subsequent amendments/integrations) relating to the protection of individuals with regard to personal data processing and Legislative Decree 196/03, as integrated by Legislative Decree 101/2018 (and subsequent amendments/integrations), authorizes the processing of data and gives consent to use thereof. The personal data requested and referred shall be used only for the full execution of this contract.

Groove

Groove



LACRUZ® SRL
Società Unipersonale

Via Concordia 16 ZI - Oderzo - TV - ITALY
Tel. +39 0422 209006 - Fax. +39 0422 810028
info@lacruz.it - www.lacruz.it

